



SKANDICA

# SPECTRUM



SPECTRUM

VESTRE

SPARTA

**SPRAWDZENIE JAKOŚCI**

**SPRAWDZENIE WYMIARÓW**

**SPRAWDZENIE NAWIERCENÍ**

**ELEMENTY WG SPECYFIKACJI**

**PROWADNICE 400 mm - 8 KOMP.**

**PŁYTA DO SZUFLAD WG. WYM. - 8szt.**

**PŁYTA TYŁ WG WYM - 2szt.**

**LISTWA ŁĄCZĄCA „H”**

**AKCESORIA**

**INSTRUKCJA**

**GWARANCJA**

**NP. PAKOWACZA**

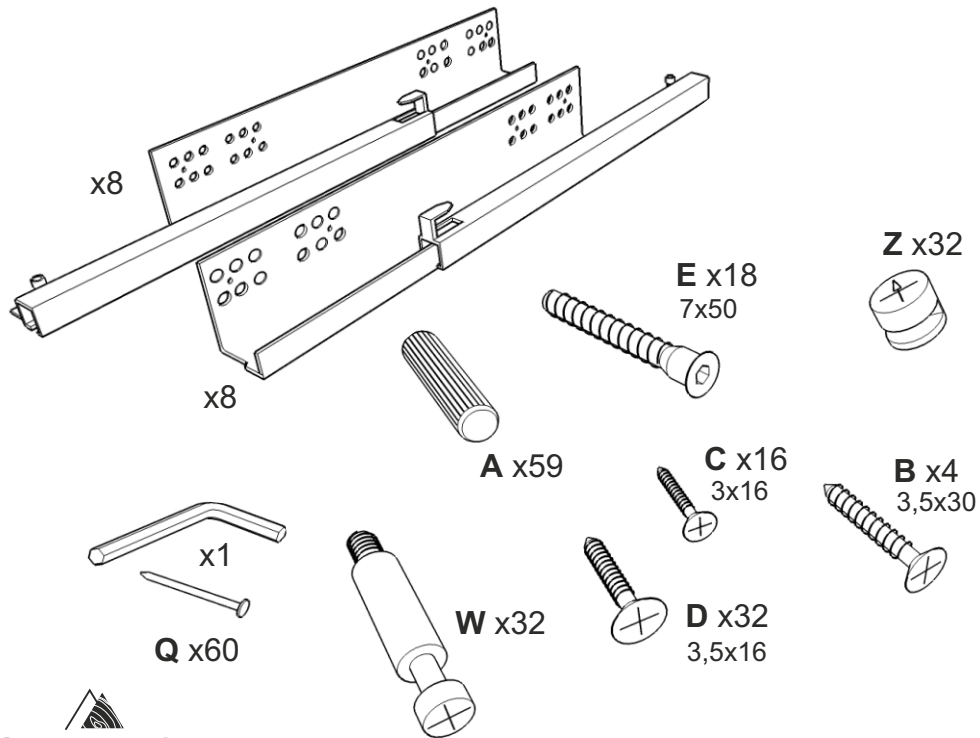
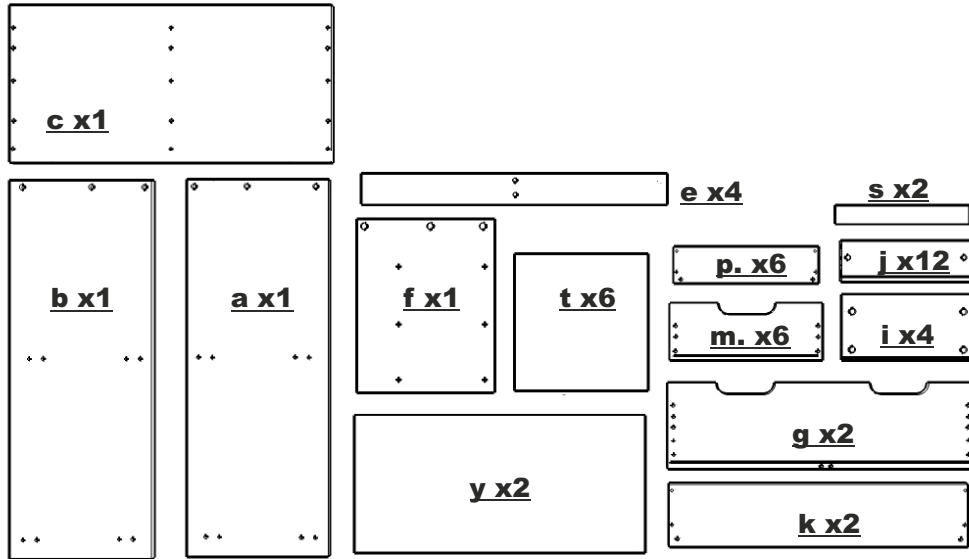

1.

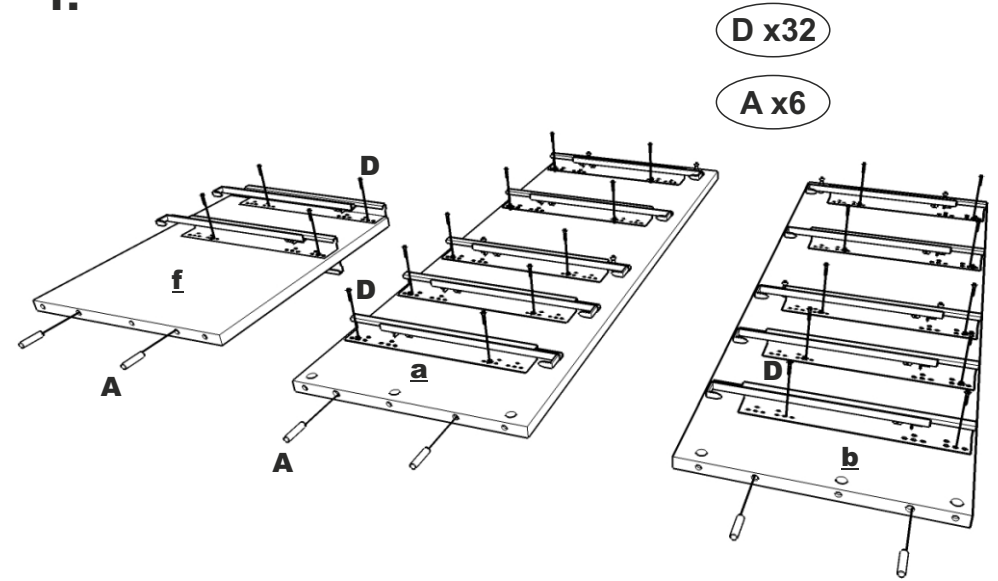

2.

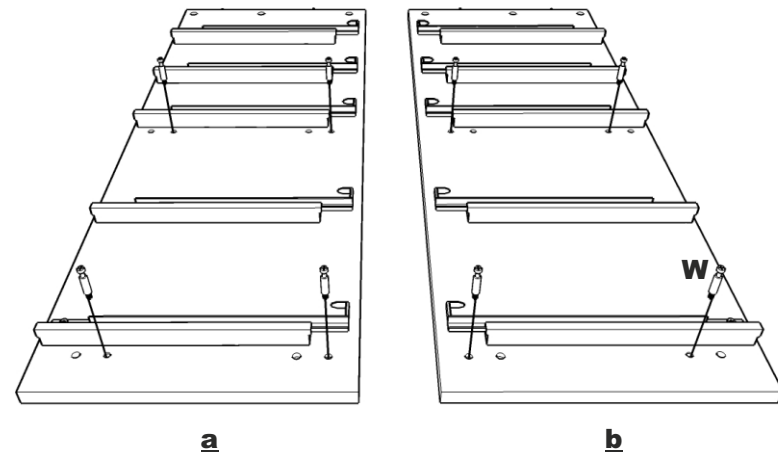

3.

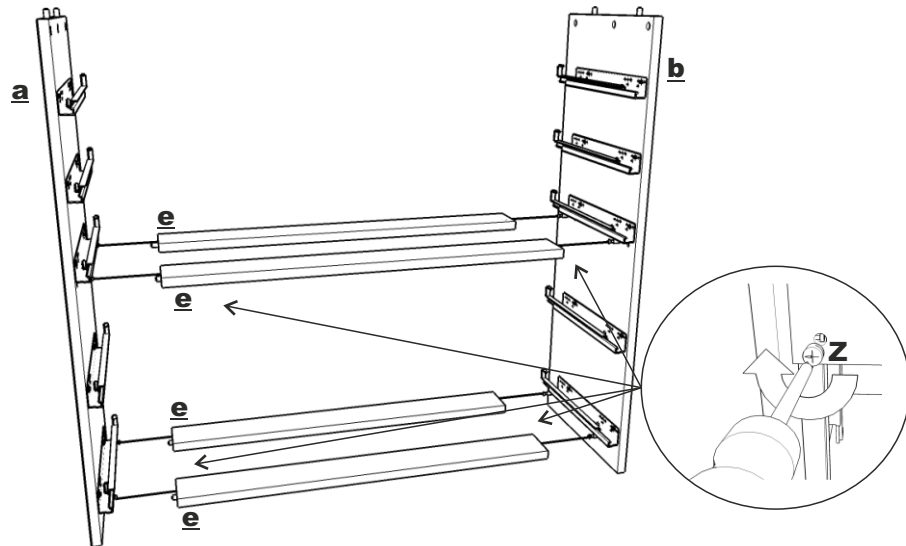

4.

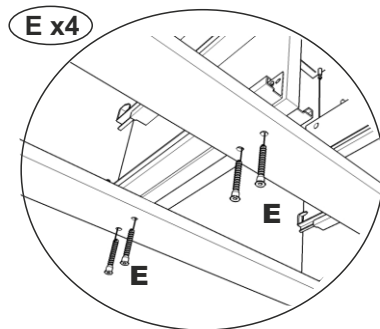
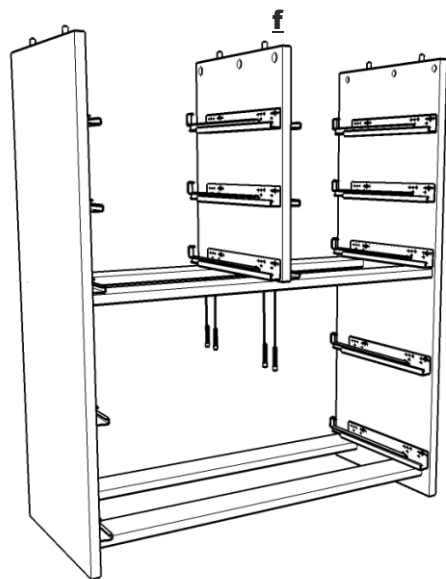

5.

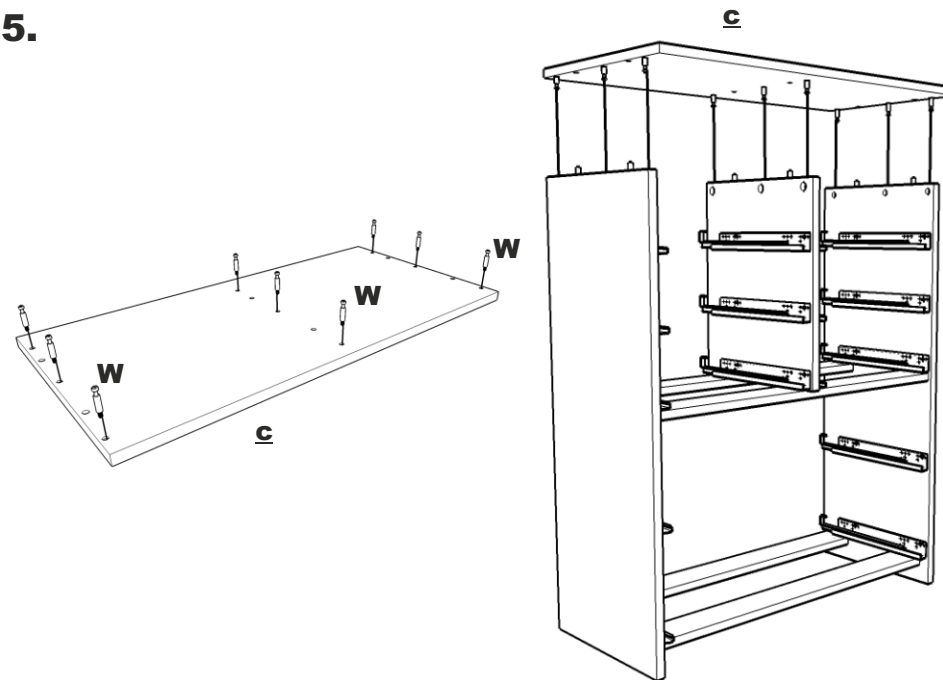

6.

